



890 Quickstart Manual

890CA (Common Bus) Adaptor

HA469250U000 Issue 1 (ISO A4)
HA469250U001 Issue 1 (American Quarto)



Contents

	Page
Safety	3
Hazards to Personnel	3
Application Risk	4
Risk Assessment	4
Accessibility	4
Protective Insulation	4
Introduction	5
About this QuickStart	5
SSD_Rail Busbar System	5
Installation	6
Dimensions	6
Ventilation.....	7
Environmental Conditions	7
Overview	8
890CA Power Connections	9
SSD_Rail Connections	10
Busbar Installation	10
Application Examples	11
Example 1: Enclosure/Row Changer (890CA///00).....	11
Example 2: Power Loss Ride-Through (890CA///RT)	12
Example 3: Connection to Non-busbar Drives	13
Drive Start-up	14
Before Applying Power :	14
Fuse Replacement	14
Common Bus Adaptor : 890CA///00	14
Common Bus Adaptor with Ride-Through : 890CA///RT	15
Appendix A: Product Code	16
Understanding the Model Number	16
Appendix B: Electrical Ratings	18
890CA Common Bus Adaptor	18
890CA Common Bus Adaptor (with Ride-Through)	18
Appendix C: Reference Information	19
890CS Common Bus Supply	19
890CD Common Bus Drive	19

Safety



This manual is for anyone installing and operating this unit.



You must be technically competent to install and operate this unit.



Before working on the unit, isolate the mains supply from terminals L1, L2 and L3 and wait 3 minutes.



Disconnect the unit from circuits when doing high voltage resistance checks.



The unit must be **permanently earthed** due to the high earth leakage current.



The drive motor must be connected to an appropriate safety earth.



Electrostatic discharge sensitive parts : observe static control precautions.



Copy existing 890 parameters to any replacement 890 unit

Hazards to Personnel

WARNING!

This equipment can endanger life through rotating machinery and high voltages. Failure to observe the following will constitute an ELECTRICAL SHOCK HAZARD.

Metal parts may reach a temperature of 70 degrees Centigrade in operation.

Before working on the equipment, ensure isolation of the mains supply from terminals L1, L2 and L3. The equipment contains high value capacitors which discharge slowly after removal of the mains supply. Wait for at least 3 minutes for the dc link terminals (DC+ and DC-) to discharge to safe voltage levels (<50V). Measure the DC+ and DC- terminal voltage with a meter to confirm that the voltage is less than 50V.



Application Risk

The specifications, processes and circuitry described herein are for guidance only and may need to be adapted to the user's specific application.

SSD Drives does not guarantee the suitability of the equipment described in the Manual for individual applications.

IMPORTANT: This product is designated as "professional equipment" as defined in EN61000-3-2. Permission of the supply authority shall be obtained before connection to the low voltage supply.

Risk Assessment

Under fault conditions, power loss or other operating conditions not intended, the system equipment may not operate as specified. In particular:

- The motor may start unexpectedly
- The motor speed may not be controlled
- The direction of rotation of the motor may not be controlled
- The motor may be energised

Accessibility

All live power terminals are IP20 rated only, since the equipment is intended to be installed within a normally-closed enclosure, which itself requires a tool to open.

Protective Insulation

- All control and signal terminals are SELV, i.e. protected by double insulation. Ensure all wiring is rated for the highest system voltage.
- All exposed metalwork in the Adaptor is protected by basic insulation and bonding to a safety earth.

Caution

This is a product of the restricted sales distribution class according to BS EN 61800-3. In a domestic environment this product may cause radio interference in which case the user may be required to take adequate measures.

Introduction

The 890 Common Bus Adaptors are designed to interconnect 890CD Common Bus Drives using the **SSD_Rail** busbar system.

Each Adaptor provides a busbar and a terminal connection for DC+ and DC-. This allows flexible wiring between rows of busbar-connected units.

Two versions are available:

1. **Enclosure/Row Changer** (890CA////00).
2. **Power Loss Ride-Through Adaptor** (890CA////RT) - contains additional bus capacitance to help a system ride-through a mains power loss, without having an under-voltage trip. Can also be used as an enclosure/row changer.

About this QuickStart

This QuickStart will:

- Familiarise you with the terminals and operation of the unit.
- Provide installation details and a quick set-up procedure.

Provided with every 890 unit is a :

- Quickstart
- 890 Installation Kit and instruction leaflet

This QuickStart assumes that:

- You are a qualified technician with experience of installing this type of equipment.
- You are familiar with the relevant standards and Local Electric Codes (which take precedence).
- You have read and understood the Safety information provided at the front of this QuickStart.
- You realise that this guide contains only basic information and that you may need to refer to the Engineering Reference Guide supplied with the 890 Drive to complete your installation.

SSD_Rail Busbar System

Since the height and depth of every module is the same, it is very convenient to assemble drives of varying frame sizes into one common bus system. Typically they are installed side-by-side.

SSD_Rail is an innovative busbar system that connects the DC+ and DC- terminals of all drives on a common bus without the use of wire.

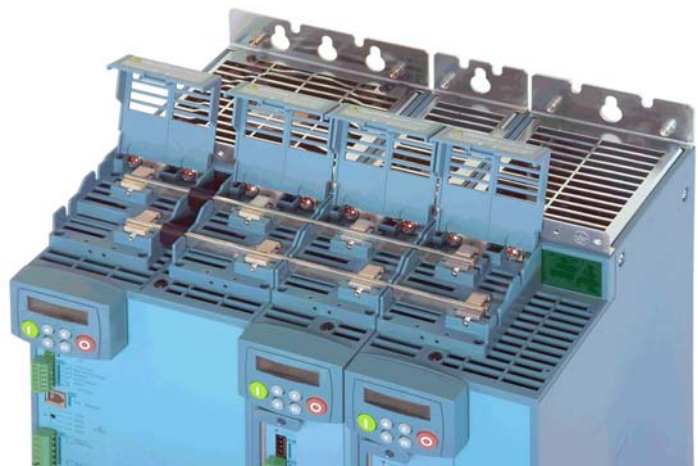

Installation

Mount the 890CA unit(s) side-by-side with the 890CD units so that the SSD_Rail busbar system can be used. The 890CA is dimensionally the same as the Frame B 890CD unit.

Dimensions

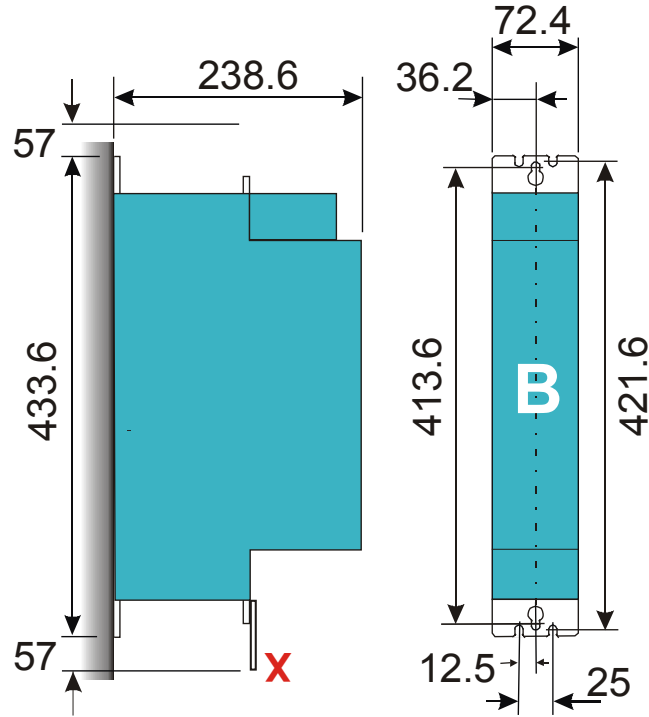

Dimensions are in millimeters (X : Power Bracket - 890 Installation Kit)

The units must be installed in an enclosure. Mount the drive using the keyholes and slots or on a 35mm DIN rail using the 890 Installation Kit supplied.

890 Installation Kit

The 890 Installation Kit is shown in the diagram attached to the bottom of the 890CA unit.

The kit provides several options for earth/ground connections. It also includes the brackets for DIN rail mounting the unit. Refer to the instructions in the kit and use the appropriate parts.

Permanent Earthing

The unit must be **permanently earthed** according to EN 50178: For permanent earthing, one conductor, PE1, of >10mm² cross-section is required; or two individual incoming protective earth conductors, PE1 & PE2, of <10mm² cross-section. Each earth conductor must be suitable for the fault current according to EN 60204.

Ventilation

The 890CA and 890CD drives can be mounted side-by-side with no clearance necessary. A minimum of 150mm (6 inches) free-air space must be allowed at the top and bottom of each drive. If mounting drives above or below other equipment, the top and bottom distances should be added for overall clearance between drives.

If connecting to a larger 690+ or 890 Frame E to K drive, also maintain the air clearance required by the larger drive. Refer to the relevant Product Manual supplied with that drive.

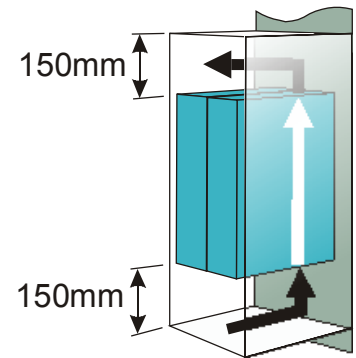

Environmental Conditions

Operating ambient temperature

0°C to 45°C (32°F to 113°F)

Enclosure rating

IP20 – UL(cUL) Open type

Atmosphere

Dust free, non flammable, non-corrosive, <85% humidity, non-condensing

Overview

890CA

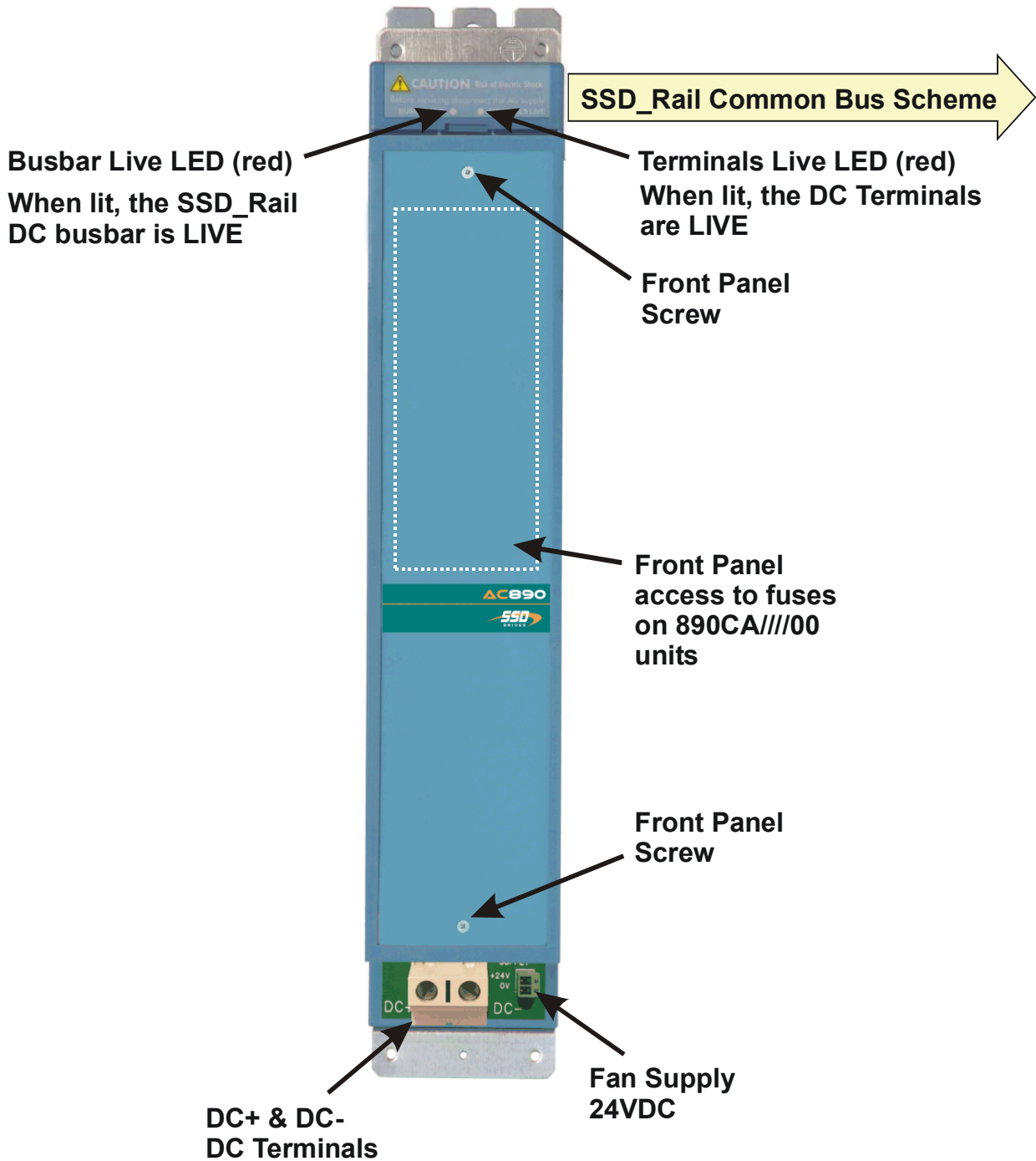

IMPORTANT: If only one LED is lit, an internal fuse has blown. Refer to page 14.

890CA Power Connections

1 Connect DC power cables to DC+ and DC- terminals.

The power **MUST** be connected DC+ to DC+, and DC- to DC-.

Maximum wire size:
Frame B: 16mm²/4AWG (stranded with ferrule)
25mm²/4AWG (solid)

2 Connect the earth/ground wire from the Supply Protective Earth/Ground to the bottom ground bracket.

Maximum wire size:
Frame B: 4mm²/12AWG

3 Connect a separate 24VDC power supply to power the internal fan. **DO NOT** use the 890CS or 890CD 24V outputs.

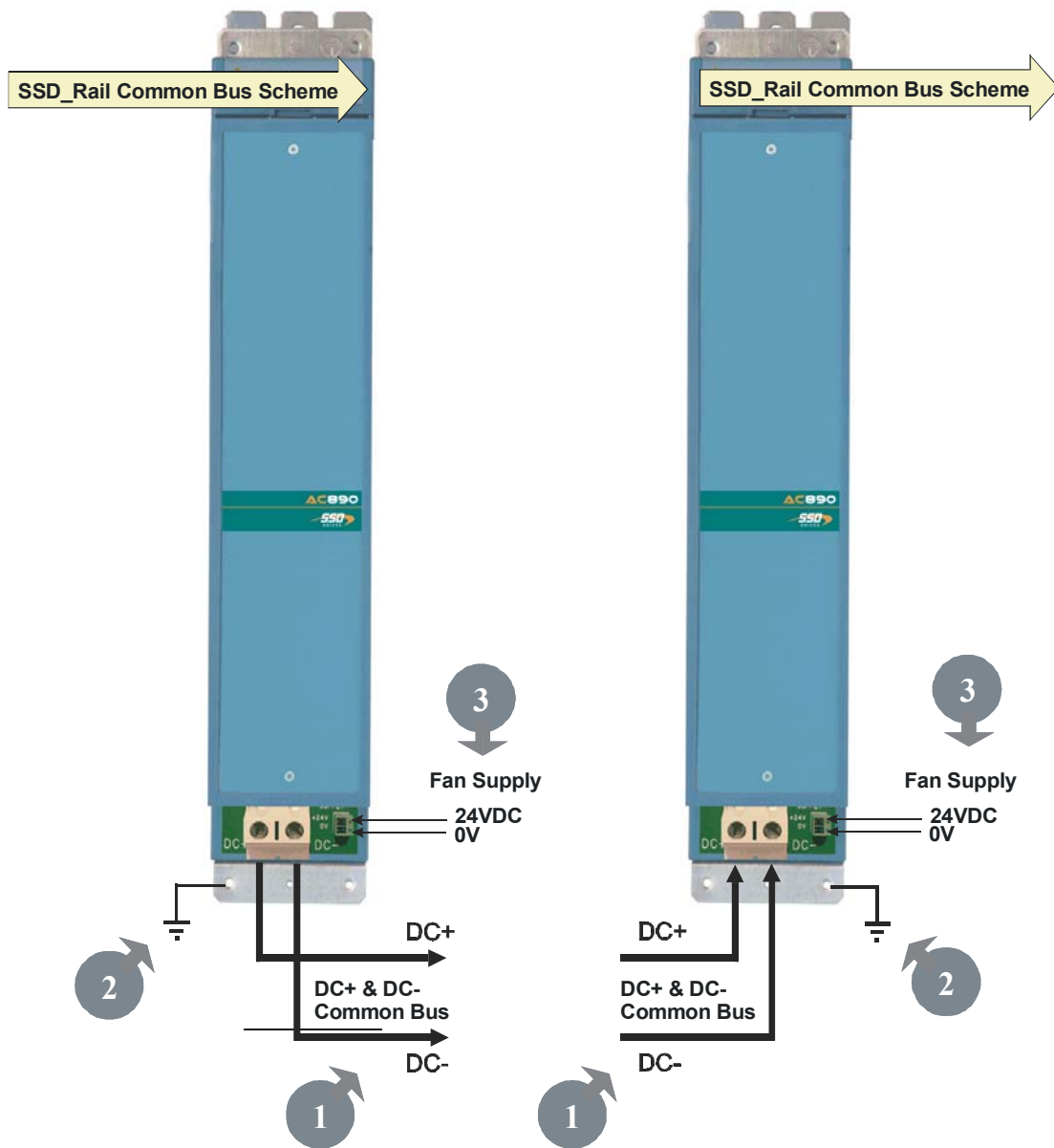

SSD_Rail Connections

WARNING!

During commissioning, remove the fuses (or trip the circuit breaker) on your 3-phase supply. Make sure the power is OFF, and that it cannot be switched on accidentally whilst you are working.

Caution

All 890 units connected to the DC bus must be rated for the same 3Ø operating voltage.

The following items are available from SSD Drives:

- Busbar : Part No. BH465850 - 1m length, 10mm x 3mm copper
- Busbar Insulator : Part No. BC465938U200 - 200mm length

The bus bar is rated at 140 Amps.

Busbar Installation

1. Simply select two correct lengths of the busbars and drop them in the slots shown in the close-up top view. Secure with two screws (2.0 Nm), shown by the arrows. Fit insulating sleeve to any busbar that protrudes from the units.
2. **For your safety and EMC compliance:**
 - ◆ **Busbar:** cut this to length so that both ends of the bar are fully inserted into a terminal –the busbar must not protrude beyond the edge of the terminal clamp if the busbar is a terminating piece.
 - ◆ **Insulator:** Fit this to all busbar external of the unit. It should butt-up to the sides of each unit. Press it firmly down onto the busbar for complete protection.
 3. Close all Busbar Terminal Covers. They snap shut.

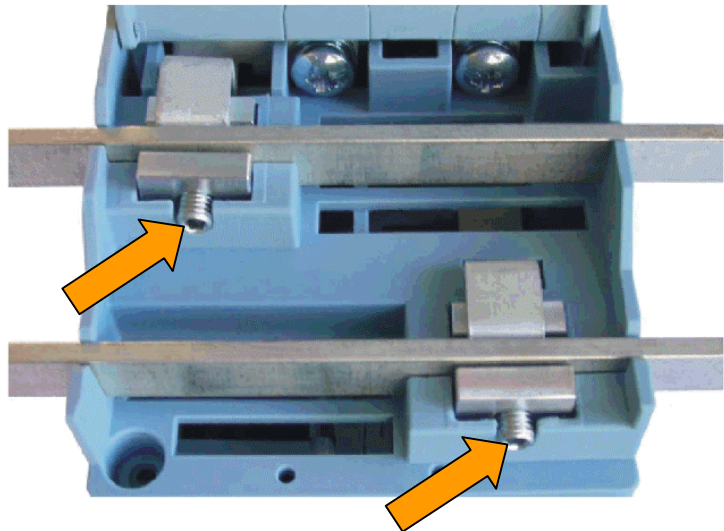

Application Examples

The 890CA unit provides a very flexible method of installing a common busbar system.

It is important to note that the Busbar is rated at 140A, so when connecting to the 890CS Frame D, which is capable of more than 140A, use both SSD_Rail connections separately.



Example 1: Enclosure/Row Changer (890CA////00)

The total loading on an 890CA unit (890CA////00) must not exceed 80A DC.

Connecting several rows of 890CD units operating from a single 890CS, or connecting parts of a common bus system in different enclosure.

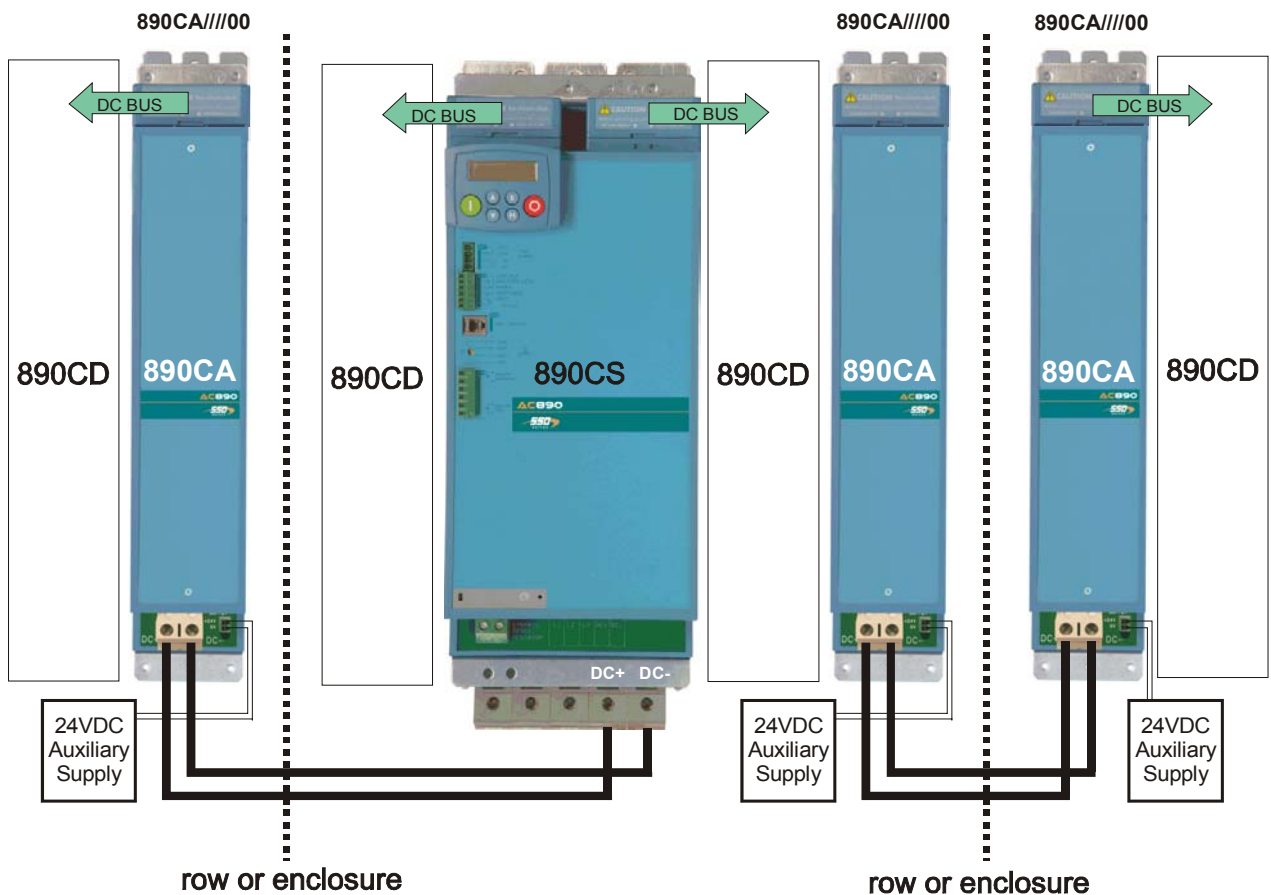

Example 1

Diagram showing connection options between the 890CS unit and the 890CA unit using SSD_Rail Busbars and/or DC+ and DC- terminals.

Example 2: Power Loss Ride-Through (890CA////RT)

The total loading on an 890CA unit (890CA////RT) must not exceed 50A DC.

A maximum of four 890CA////RT units may be used in a system. 890CA////RT units can also be used as "row-changers".

The capacitors in the 890CA (890CA////RT) provide additional bus capacitance. This will increase the time before experiencing an under-voltage trip in the event of a mains power loss.

To ensure an acceptable life-time for the capacitors in the unit, we recommend that the total loading on an 890CA (890CA////RT) does not exceed 50A DC.

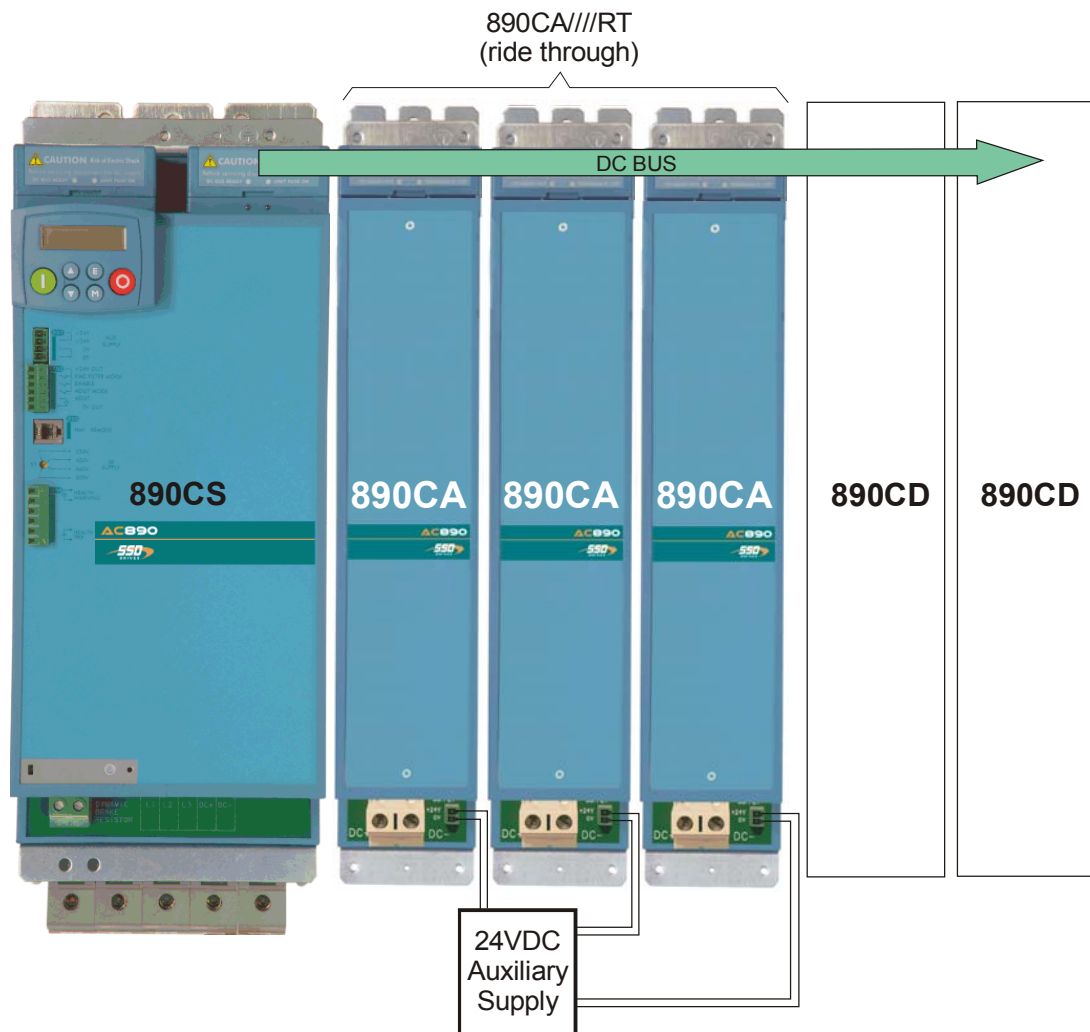

Example 2

Diagram showing 890CA units with Ride-Through connected between the 890CS and 890CD units.

Example 3: Connection to Non-busbar Drives

The total loading on an 890CA unit (890CA////00) must not exceed 80A DC.

The total loading on an 890CA unit (890CA////RT) must not exceed 50A DC.

Connecting 890CD units to an alternative DC source. For example, a 690+ drive that may be acting as a regenerative front-end.

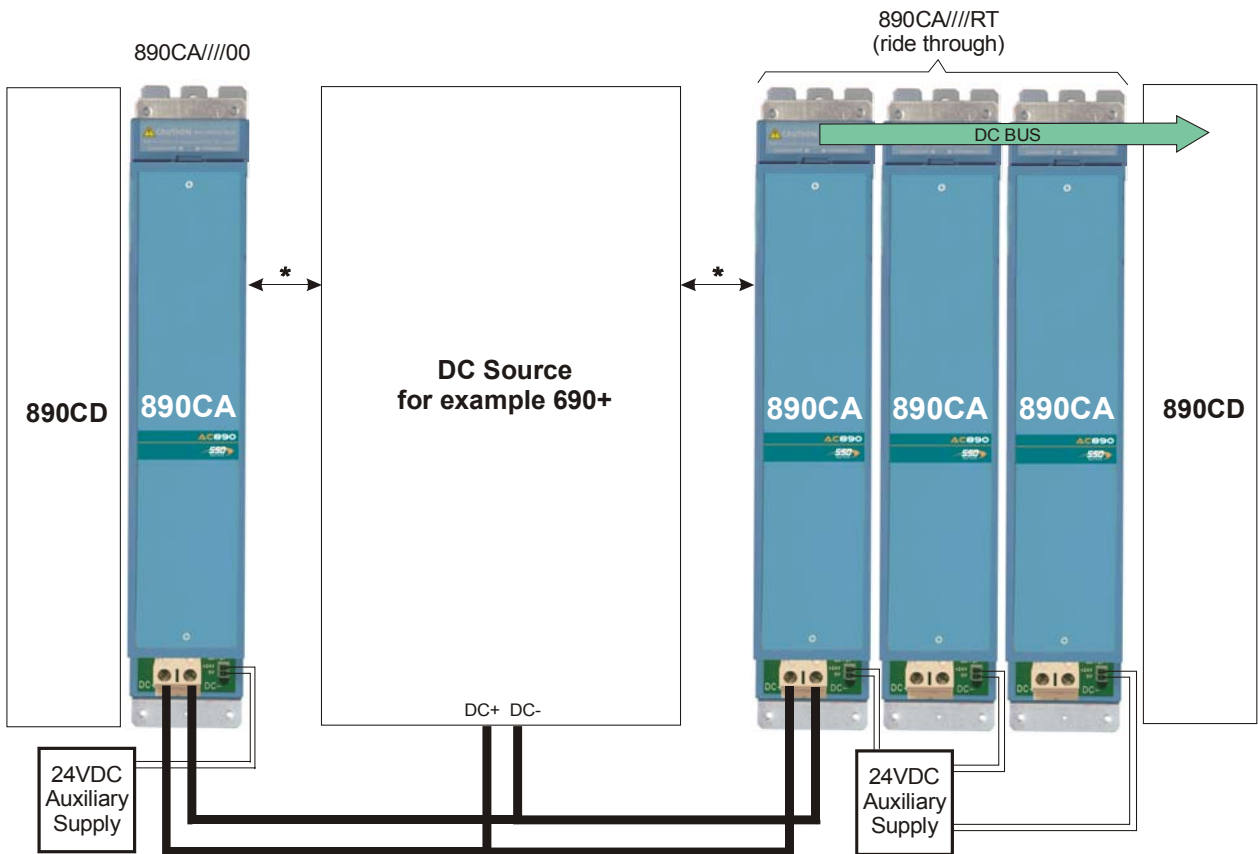

Example 3

Diagram showing connection between the DC+ and DC- terminals of an alternative DC source and an 890CA unit.

* Note that the air clearance for the drive must be maintained. Refer to the relevant product manual for details.



Drive Start-up

Before Applying Power :

- Read the Safety section at the front of the QuickStart.
- Ensure that all local electric codes are met.
- Check for damage to equipment.
- Check for loose ends, clippings, filings, drilling swarf etc. lodged in the drive and system.
- Check all external wiring circuits of the system - power, control, motor and earth connections.
- Ensure that the fan in the 890CA unit is functioning.
- Ensure that the SSD_Rail has been correctly installed and securely fastened.

Fuse Replacement

WARNING!

During commissioning, remove the fuses (or trip the circuit breaker) on your 3-phase supply. Make sure the power is OFF, and that it cannot be switched on accidentally whilst you are working.

The equipment/system contains high value capacitors which discharge slowly after removal of the mains supply. Wait for at least 3 minutes for the dc link terminals (DC+ and DC-) to discharge to safe voltage levels (<50V). Measure the DC+ and DC- terminal voltage with a meter to confirm that the voltage is less than 50V.

The 890CA is internally fused with two 100 Amp fast-blow fuses, FS1 and FS2: SSD Part Number CS465994U100. If one LED is not lit, then a fuse has blown.



Common Bus Adaptor : 890CA///00

The fuses can be replaced with the unit *in situ*.

1. Remove the two screws securing the unit's front panel. Remove the panel to reveal the fuses.
2. Replace the fuses. Be careful not to drop fuse fastenings inside the unit.
3. Replace the front panel and secure with the screws.

Common Bus Adaptor with Ride-Through : 890CA////RT

The unit must be dismantled to gain access to the fuses.

1. Dismantle the unit from the system to work with it on a bench.
2. Open the top cover of the SSD_Rail connection box by inserting a large flat blade screw driver into the slot at the front and prising open.
3. Remove the two large screws (**A** - Posidrive No. 2).
4. Undo the four screws (**B** - Torx T10) securing the connection box and remove the connection box.
5. Locate the four black plastic rivets (**C** - two on the top, two on the bottom of the unit). These are a two part fastener comprising a central rivet and a collet. With a small flat blade screw driver prise out the rivet and remove the collet from the hole.
6. Remove the four screws (Torx T20) from the right hand side of the drive when viewed from the front.
7. Remove the side of the drive.
8. Replace the fuses. Be careful not to drop fuse fastenings inside the unit.
9. Fit the side on the drive.
10. Fit the side on the drive and secure with the four screws (Torx T20).
11. Fit the four black plastic fasteners (**C**). Ensure the holes in the mouldings are lined up for an easier fit.
12. Fit the SSD-Rail connection box and secure with the four screws (**B**).
13. Fit the large screws in the back of the connection box (**A**). It is important that these screws are tightened to 3Nm.

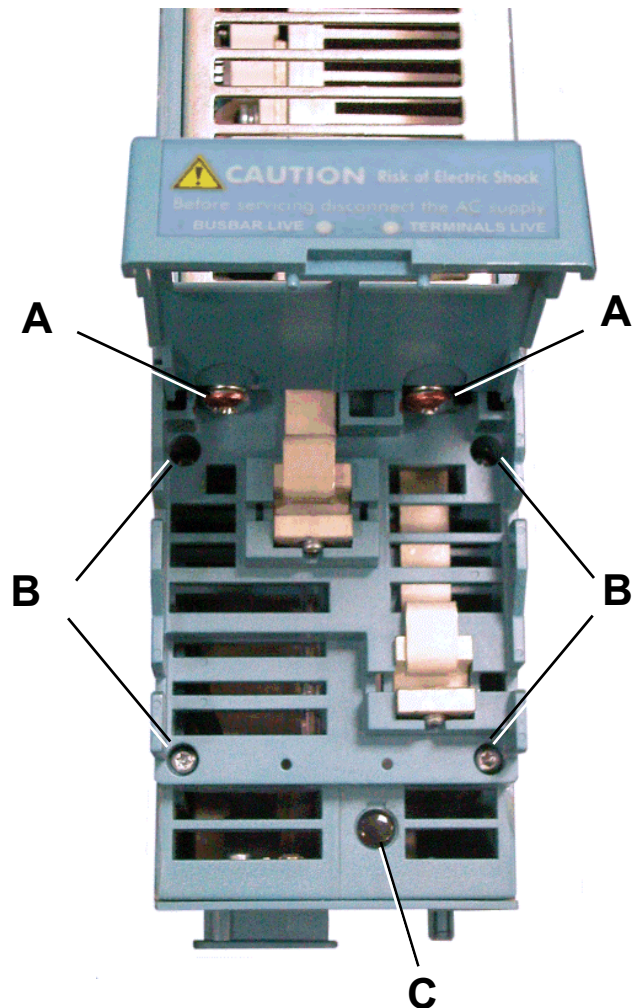



Appendix A: Product Code

Understanding the Model Number

Each unit is identified using an alphanumeric code which records how the unit was configured when dispatched from the factory. Each block of the Model Number is identified as below using a 7 block short code (shaded) and a 9 block long code. The short code defines the "base build" product and the long code defines the configuration including options.

Example Model Number:



<i>Block 1</i>	890CA	This is an 890CA Common Bus Adaptor
<i>Block 2</i>	5	Nominal input voltage rating is 500Vac
<i>Block 3</i>	0080B	Current rating (continuous output RMS Amps) : 80 Amps DC Physical frame size B
<i>Block 4</i>	N	Braking Control : No Braking Control
<i>Block 5</i>	00	Build Option : Not applicable
<i>Block 6</i>	N	Performance Level : Not applicable
<i>Block 7</i>	US	English documentation
<i>Block 8</i>	00	SSD standard livery
<i>Block 9</i>	00	Special options : none fitted

Model Number		
Block	Variable	Description
1	89xXX	Generic product: 890 = Standard Product 891 = Conformal Coated PCB's 89xCA = Common Bus Adaptor
2	X	One number specifying the nominal input voltage rating: 5 = 500 Vac
3	XXXXX	Four numbers specifying the nominal current in Amps and one character indicating size frame 0050B = 50 Amp DC with additional bus caps: Frame B 0080B = 80 Amp DC no additional bus caps: Frame B
4	X	One character specifying the Dynamic Braking Option: N = No Braking Control
5	XX	Two characters specifying the build option: 00 = Not applicable RT = Ride-Through Capacitors (890CA, 50A rating only)
6	X	One character specifying the Performance Level: N = Not applicable
7	XX	Two characters specifying the destination: EN = English FR = France GR = Germany IT = Italy SW = Sweden
8	XX	Two characters specifying the livery (Brand Label Partners - 01 thru 99): 00 = SSD Standard
9	XX	Two characters specifying special options: 00 = None fitted



Appendix B: Electrical Ratings

890CA Common Bus Adaptor

Output current must not be exceeded under steady state operating conditions. Operating voltage is 230V to 500Vac \pm 10%.

Model Number		890CA/5/0080B/N/00
Nominal Operating Voltage	Vac	230-500
Input Current (DC)	A	80A
Output Current (DC)	A	80A

890CA Common Bus Adaptor (with Ride-Through)

Output current must not be exceeded under steady state operating conditions. Operating voltage is 230V to 500Vac \pm 10%.

The units can be operated in parallel for increased ride-through capability up to a maximum of 4 modules.

Model Number		890CA/5/0050B/N/RT
Nominal Operating Voltage	Vac	230-500
Input Current (DC)	A	80A
Output Current (DC)	A	50A
Fuses: FS1 & FS2		100A : SSD Part Number CS465994U100
Module Capacitance	mF	3.1
Power Loss Ride-Through Energy		138J @ 400Vac, 192J @ 460Vac

Appendix C: Reference Information

890CS Common Bus Supply

Output current must not be exceeded under steady state operating conditions. Output overload 150% overload for 60 seconds.

		Frame B		Frame D	
Model Number		890CS/5/0032B	890CS/5/0054B	890CS/5/0108D	890CS/5/0162D
Nominal Operating Voltage	Vac	208-500 ±10%			
Input Current (AC)	A	32	54	108	162
Continuous RMS Output Current (DC)	A	40	65	135	200

890CD Common Bus Drive

Motor power, input current and output current ratings must not be exceeded under steady state operating conditions. Vector Mode 150% overload for 60 seconds. Servo Mode 200% overload for 4 seconds.

FRAME B Input currents listed at 560V DC (from 400Vac) and 650V DC (from 460-500Vac) assuming a total source impedance of 800μH.

Model Number		890CD/5/0002B		890CD/5/0003B		890CD/5/0004B		890CD/5/0006B	
Nominal Supply Voltage	Vdc	560	650-705	560	650-705	560	650-705	560	650-705
Input Current - Vector Mode	A	2.9	2.8	5	4.9	6.6	6.5	8.6	7.2
Model Number		890CD/5/0010B		890CD/5/0012B		890CD/5/0016B		890CD/5/S016B	
Nominal Supply Voltage	Vdc	560	650-705	560	650-705	560	650-705	560	650-705
Input Current - Vector Mode	A	14.1	11.3	16.8	16.6	22.2	19.5	24*	21.2*

* Values are for "Input Current - Servo Mode".

FRAME C Input currents listed at 560V DC (from 400Vac) and 650V DC (from 460-500Vac) assuming a total source impedance of 800μH.

Model Number		890CD/5/0024C		890CD/5/0030C		890CD/5/S030C	
Nominal Supply Voltage	Vdc	560	650-705	560	650-705	560	650-705
Input Current - Vector Mode	A	33	28	43	36	43	36

FRAME D Input currents listed at 560V DC (from 400Vac) or 650V DC (from 460-500Vac) assuming a total source impedance of 190μH.

Model Number		890 CD/5/0039D		890CD/5/0045D		890/5/0059D	
Nominal Supply Voltage	Vdc	560	650-750	560	650-705	560	650-705
Input Current - Vector Mode	A	44	41	51	46	66	59



890CD Common Bus Drive

Motor power, input current and output current ratings must not be exceeded under steady state operating conditions. Vector Mode 150% overload for 60 seconds. Servo Mode 200% overload for 4 seconds.

FRAME E Input currents listed at 560V DC (from 400Vac), 650V DC (from 460Vac) and 705V DC (from 500V AC) assuming a total source impedance of 800 μ H.

Model Number		890CD/4/0073E			890CD/4/0087E		
Nominal Supply Voltage	Vdc	560	650	705	560	650	705
Input Current - Vector Mode	A	82	72	66	100	87	80

FRAME F Input currents listed at 560V DC (from 400Vac), 650V DC (from 460Vac) and 705V DC (from 500V AC) assuming a total source impedance of 800 μ H.

Model Number		890CD/4/0105F			890CD/4/0145F		
Nominal Supply Voltage	Vdc	560	650	705	560	650	705
Input Current - Vector Mode	A	123	107	98	166	144	133

Model Number		890CD/4/0156F			890CD/4/0180F		
Nominal Supply Voltage	Vdc	560	650	705	560	650	705
Input Current - Vector Mode	A	203	176	162	203	213	-