



---

# **L5354 ControlNet Communications Interface**

Technical Manual

HA470733 Issue 3

© Copyright SSD Drives Inc 2007

All rights strictly reserved. No part of this document may be stored in a retrieval system, or transmitted in any form or by any means to persons not employed by a SSD group company without written permission from SSD Drives Inc.

Although every effort has been taken to ensure the accuracy of this document it may be necessary, without notice, to make amendments or correct omissions. SSD Drives cannot accept responsibility for damage, injury, or expenses resulting therefrom.



# Safety Information



Please read this information **BEFORE** installing the equipment.

## Intended Users

This manual is to be made available to all persons who are required to install, configure or service equipment described herein, or any other associated operation.

The information given is intended to highlight safety issues, and to enable the user to obtain maximum benefit from the equipment.

## Application Area

The equipment described is intended for industrial motor speed control using DC or AC motor controllers, with DC motors AC induction or AC synchronous machines.

## Personnel

Qualified personnel should carry out installation, operation and maintenance of the equipment. A qualified person is someone who is technically competent and familiar with all safety information and established safety practices; with the installation process, operation and maintenance of this equipment; and with all the hazards involved.

**REFER TO YOUR MAIN PRODUCT MANUAL FOR SPECIFIC SAFETY INFORMATION ABOUT THE DEVICE YOU ARE CONTROLLING**

## IMPORTANT

*It is required that the users have DSD, RSLogix 5000 and RS Network for ControlNet installed on a computer and have a working knowledge of these software packages.*

## ACKNOWLEDGEMENTS

Drive System Designer, DSD is a registered trademark of SSD Drives Inc.

RSLogix 5000, ControlLogix500, and RSNetwork for ControlNet are registered trademarks of Allen-Bradley Inc.



# Table of Contents

---

<b>Chapter 1 System Overview</b> .....	<b>1</b>
Product Features.....	1
Product Code .....	1
DSD Requirements .....	1
Wiring the System .....	1
<b>Chapter 2 Hardware Installation</b> .....	<b>2</b>
Installing and Connecting the ControlNet LinkCard.....	2
Installing the ControlNet LinkCard .....	2
Initial Power on Checks.....	3
Understanding the LED Indications .....	3
Network and Module LED Indications.....	3
<b>Chapter 3 Configuring the LinkRack</b> .....	<b>4</b>
<b>Chapter 4 Configuring the PLC/SCADA Supervisor</b> .....	<b>6</b>
<b>Chapter 5 Configuring RSNetworx for ControlNet</b> .....	<b>10</b>
<b>Appendix A Configuration Tips</b> .....	<b>12</b>
<b>Appendix B Troubleshooting</b> .....	<b>13</b>
L5354 Module Status LED .....	13
<b>Technical Specifications</b> .....	<b>14</b>
Environmental .....	14
Supply Voltage .....	14
Physical.....	14

# Chapter 1 System Overview

---

## Product Features

- Suitable for use with Link modules:
  - L5392      LinkStation
  - L5300      LinkRack
- Connection using RG 59 (75Ω) double shielded coaxial cable
- LED's to indicate board and communications status
- Configured using Function Block inputs and outputs
- Diagnostics using Function Block outputs
- Automatic Baud Rate selection
- Software-selectable Slave Address
- The ControlNet LinkCard is provided as a plug-in LinkCard.
- ControlNet.eds file is provided with the LinkCard.
- 224 words in and out.

## Product Code

Part Number: L5354 ControlNet LinkCard

## DSD Requirements

Software version: 1.13 or higher.

Database level: 1037 or higher.

## Wiring the System

### **WARNING!**

Before installing, ensure that the LinkRack wiring is electrically isolated and cannot be made "live" unintentionally by other personnel.

Wait 5 minutes after disconnecting power before working on any part of the system or removing the covers from the drives.

## Chapter 2 Hardware Installation

### Installing and Connecting the ControlNet LinkCard

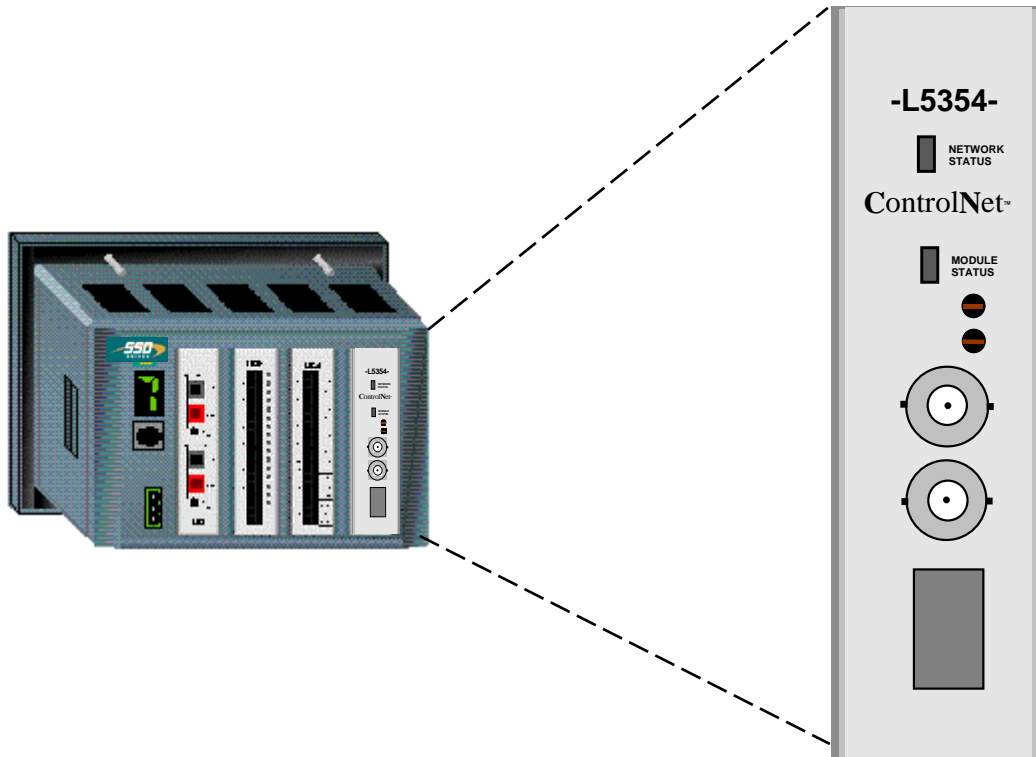

Figure 1. L5392 LinkStation with L5354 ControlNet LinkCard

#### **WARNING!**

Prior to starting work on the LinkRack or LinkStation ensure all sources of power are isolated.



### Installing the ControlNet LinkCard

The ControlNet LinkCard plugs into a LinkRack or a LinkStation. The ControlNet LinkCard can be installed into any site (J1, J2, J3, and J4) of the LinkRack.

- Remove the back cover of the LinkRack
- Insert the ControlNet card into the recess on the back of the LinkRack.
- Re-fit the back cover to the LinkRack
- Make all user-wiring connections. Refer to Wiring Diagram, Figure 3.

### Initial Power on Checks

With the correct connections to the active PLC/SCADA supervisor, the MODULE LED will be ON continuously and the NETWORK LED will flash to indicate the No Connection State.

ON		MODULE LED
FLASH		NETWORK LED

## Understanding the LED Indications

### Network and Module LED Indications



		Network LED	Module LED	
		Indicates the state of the connected network.	Indicates the set-up state of the LinkCard. The states indicated are those produced by the FAULT parameter of the LinkCard function block.	
LED Indication	Description	FAULT Parameter	Description	
OFF 	Disabled	HARDWARE	Hardware Fault - external	
FLASH 	No Connection	CONFIGURING	Card is initializing	
ON 	Data exchange	NONE	Valid set-up, ready for external communications	

Figure 2. LED Status Indication

Note: The NETWORK LED is always in the OFF State when the MODULE LED is **not** ON continuously, indicating that the LinkCard is not receiving external communications or the PLC is off.

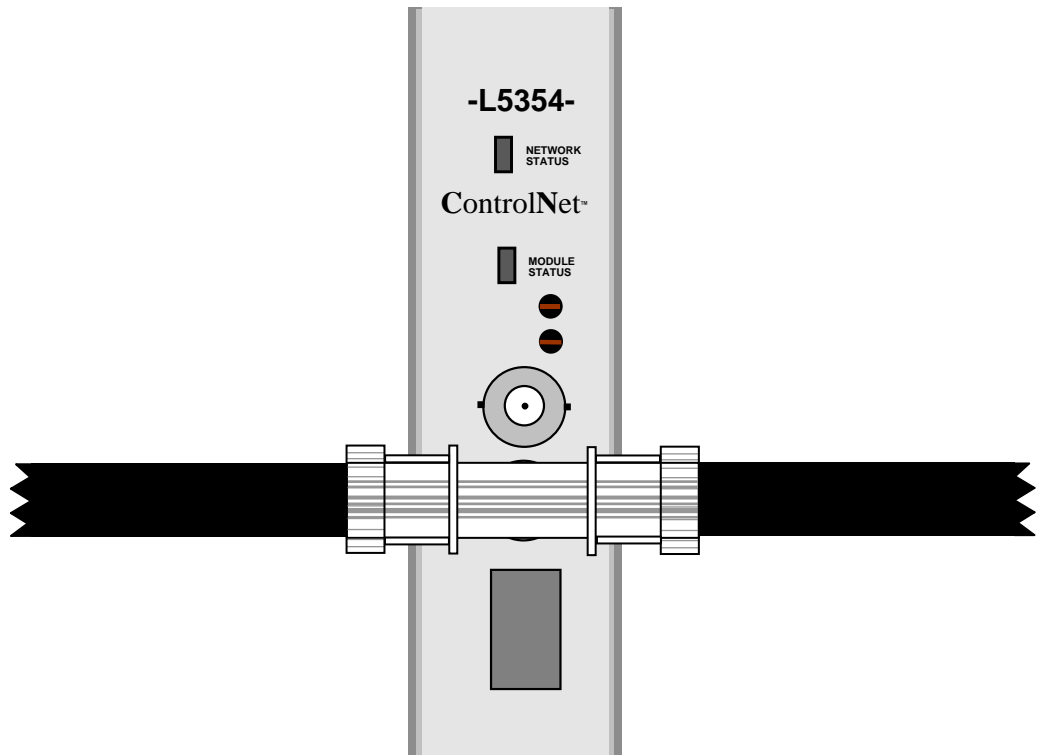
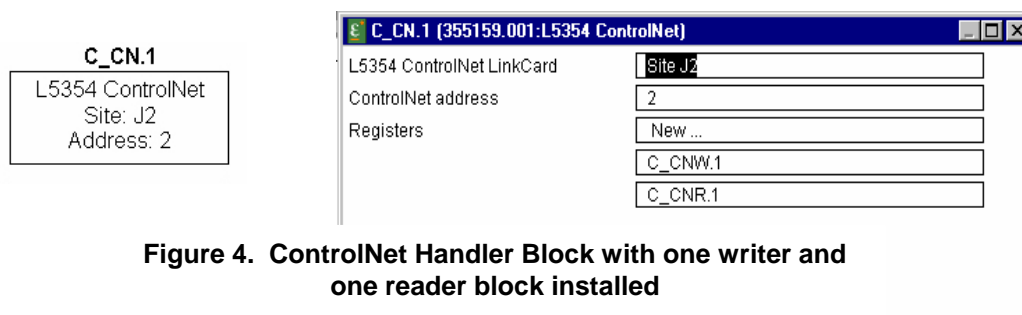

Figure 3. ControlNet connections to the L5354

## Chapter 3 Configuring the LinkRack

1. Create the LINK configuration with all the reader and writer blocks that are required for the project. Placing other function blocks into the LINK module will decrease performance. Insert the writer blocks before inserting the reader blocks into the handler. The LinkCard transmits and receives the data in the order in which the blocks are inserted into the handler.
2. The LINK ControlNet handler block identifies the slot location in the LinkRack/LinkStation and the ControlNet node address on your ControlNet network. The node address is not hardware selected; the two rotary switches on the L5354 are set to 00.



**Figure 4. ControlNet Handler Block with one writer and one reader block installed**

3. Load the LINK configuration first. The PLC will connect once its configuration is installed. The connection to the LINK module will equal the PLC configuration size. If the PLC configuration is smaller than the LINK configuration, there will be no I/O error and only the PLC configured data will be transmitted.

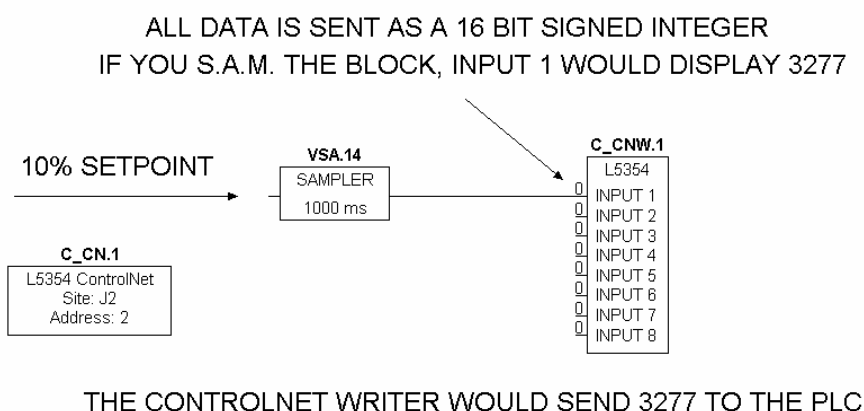

**Figure 5. Basic LINK Setup**

Note: The above LINK configuration is sending a value signal (16 bit) to the PLC.

1% = 328	-1% = 65209
10% = 3277	-10% = 62259
100% = 32767	-100% = 32769

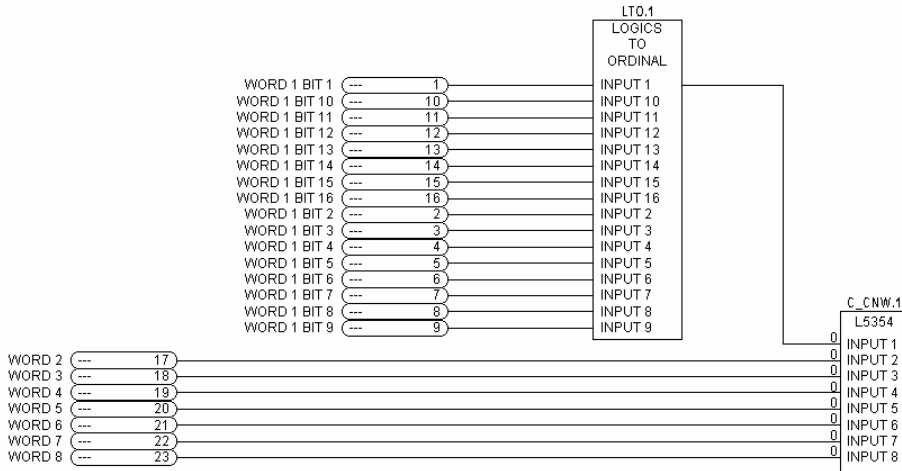

Figure 6. Logical to Ordinal and Value LINK Setup

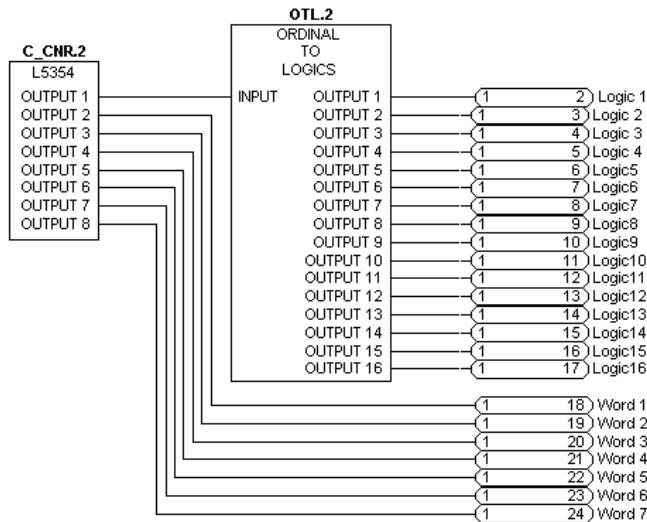

Figure 7. Ordinal to Logical and Value LINK Setup

Note: The above configurations are sending seven values and 16 Boolean signals from within the LINK network to the ControlNet network and from the ControlNet network to the Link network. The Logics to Ordinal and the Ordinal to Logics function blocks multiplexes and demultiplexes the 16 Boolean signals into one word.

## Chapter 4 Configuring the PLC/SCADA Supervisor

Our example will use the RSLogix 5000 software and ControlLogix PLC.

1. Start a new program and select the PLC processor and chassis type that will be used in your project. Our example will use a 1756-L55 processor and 1756-A7 chassis. Remain Offline until you are ready to download the program.
2. In the I/O configuration, select the ControlNet scanner. Right click on the I/O Configuration folder to select a New Module. Select the type of scanner module that will be used in the PLC.

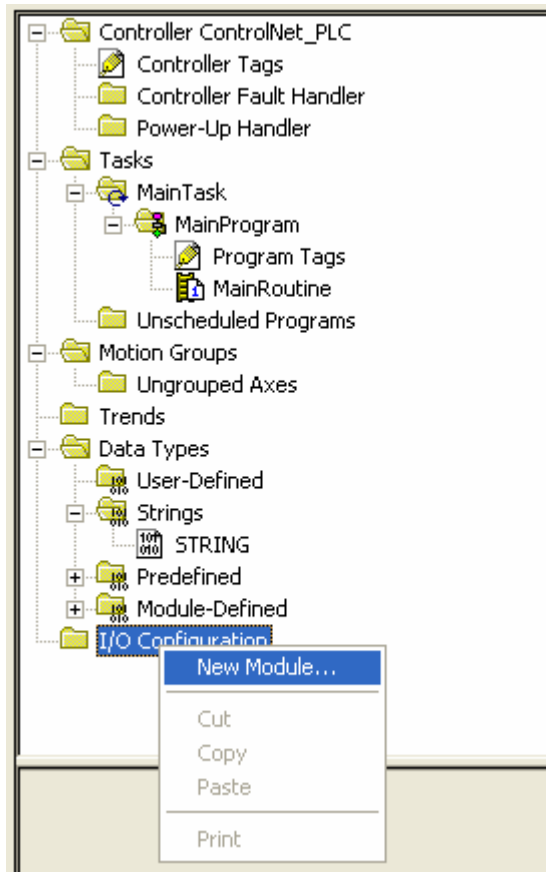

Figure 8. Selecting New Module

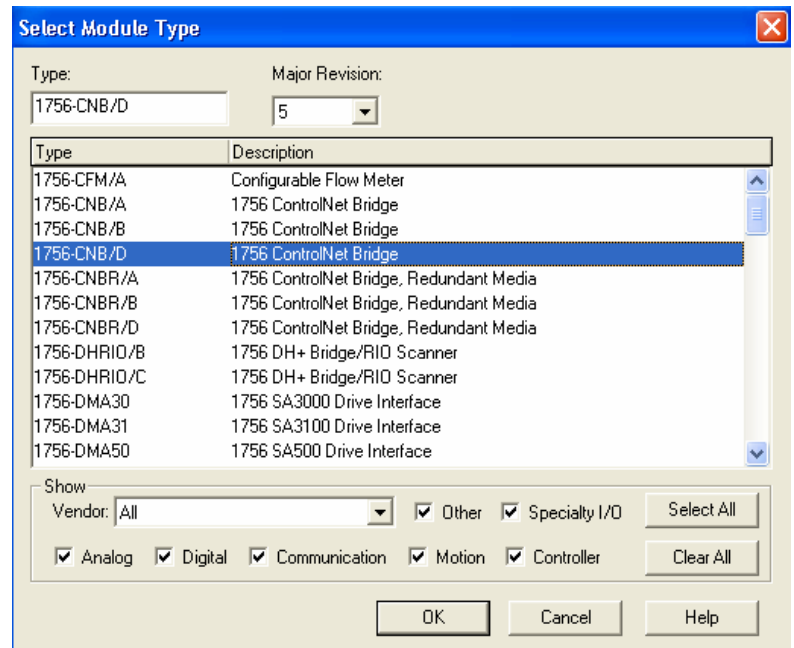
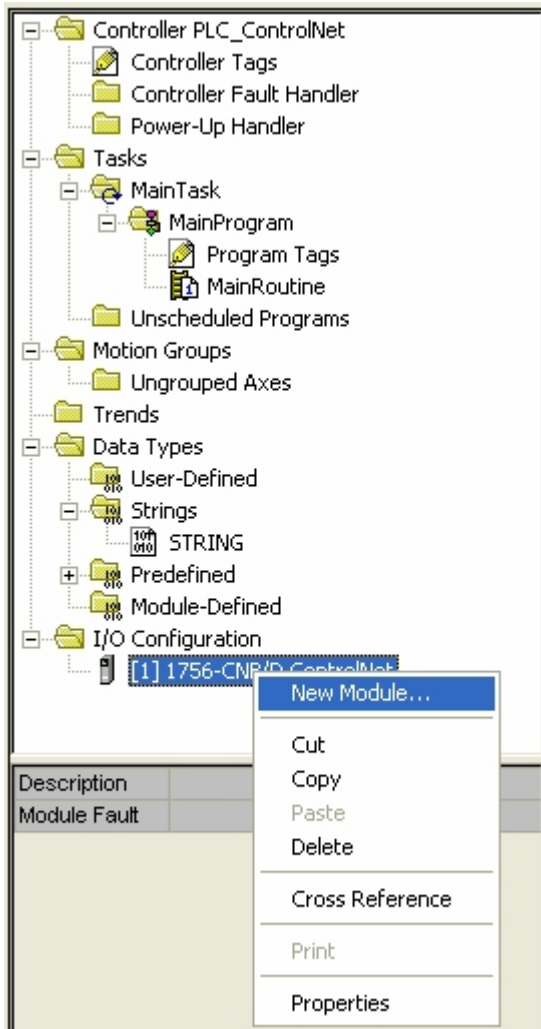
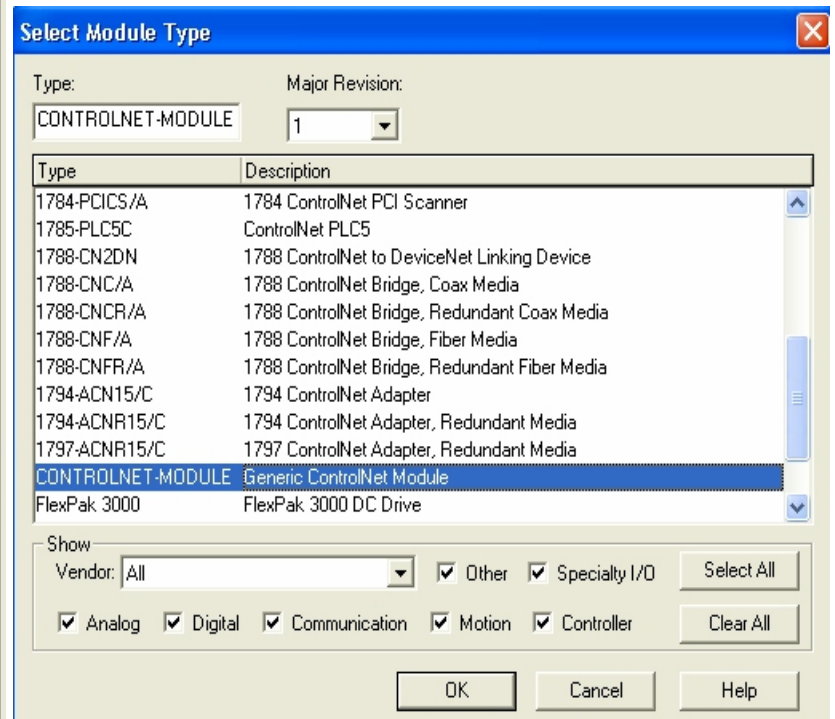

Figure 9. Select Scanner

- Under the scanner card, add a new module. Right click on the scanner module and select New Module. Select Generic ControlNet module.



**Figure 10. Select New Remote Module**



**Figure 11. Select Remote Module Type**

- This window allows you to name the module and to set network address, set data type (data-int), and set data size. The input assembly instance is 100 and the size is the configured number of words plus 2. The output assembly instance is 150 and the size is the number of words you are sending to LINK. The configuration assembly instance is 1 and the size is 0. The Comms Format is set for "DATA-INT" to allow transferring 16 bit words. Refer to Figure 12.
- Click the NEXT button to set the Requested Packet Interval time. The default setting should be sufficient for most applications. When finished with the Requested Packet Interval screen, click the FINISH button to exit. Refer to Figure 13.

**Module Properties - ControlNet (CONTROLNET-MODULE 1.1)**

Type: CONTROLNET-MODULE Generic ControlNet Module  
 Parent: ControlNet

Name: L5354\_Link\_Rack  
 Description: ControlNet Interface to Link  
 Comm Format: Data - INT  
 Node: 3

**Connection Parameters**

Parameter	Assembly Instance	Size
Input	100	10 (16-bit)
Output	150	8 (16-bit)
Configuration	1	0 (8-bit)
Status Input		
Status Output		

Buttons: Cancel, < Back, Next >, Finish >>, Help

**Figure 12. Defining the Module Name and Data Size**

**Module Properties - ControlNet (CONTROLNET-MODULE 1.1)**

Requested Packet Interval (RPI): 5.0 ms (2.0 - 3200.0 ms)

Inhibit Module  
 Major Fault On Controller If Connection Fails While in Run Mode

Module Fault

Buttons: Cancel, < Back, Next >, Finish >>, Help

**Figure 13. Packet Rate Selection**

6. The RSLogix 5000 program will configure your data types and I/O data points automatically.
7. Once the PLC is configured for the LinkCard, the program can be downloaded to the PLC. The program needs to be loaded before RSNetWorx can create the proper configuration for the ControlNet network.
8. The PLC automatically creates a configuration data block. The block is always ends a “C”. This block is part of every configuration. L5354\_LinkCardC: 0 was created for this module. The type and size of the data is fixed, (Type: SINT, Size: 400 bytes). This configuration data block is created regardless of the configuration size.

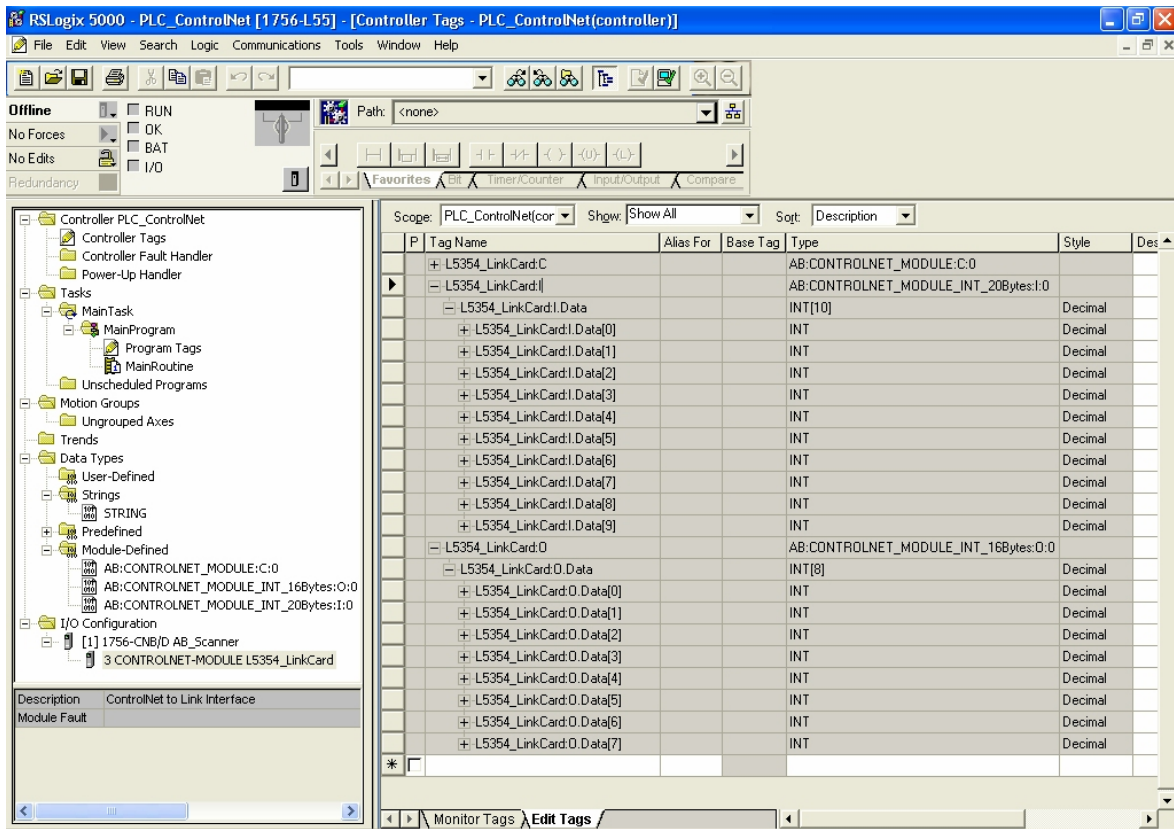

Figure 14 ControlNet Data allocations for the PLC

## Chapter 5 Configuring RSNetworkx for ControlNet

The fastest way to configure the ControlNet scanner is online with RSNetworkx and all the nodes connected to the network.

1. Load the EDS file for the LinkCard first. A diskette is included with the L5354 LinkCard that contains the ControlNet.eds file. Using the Tools menu, select EDS Wizard. The EDS wizard will guide you through the process.

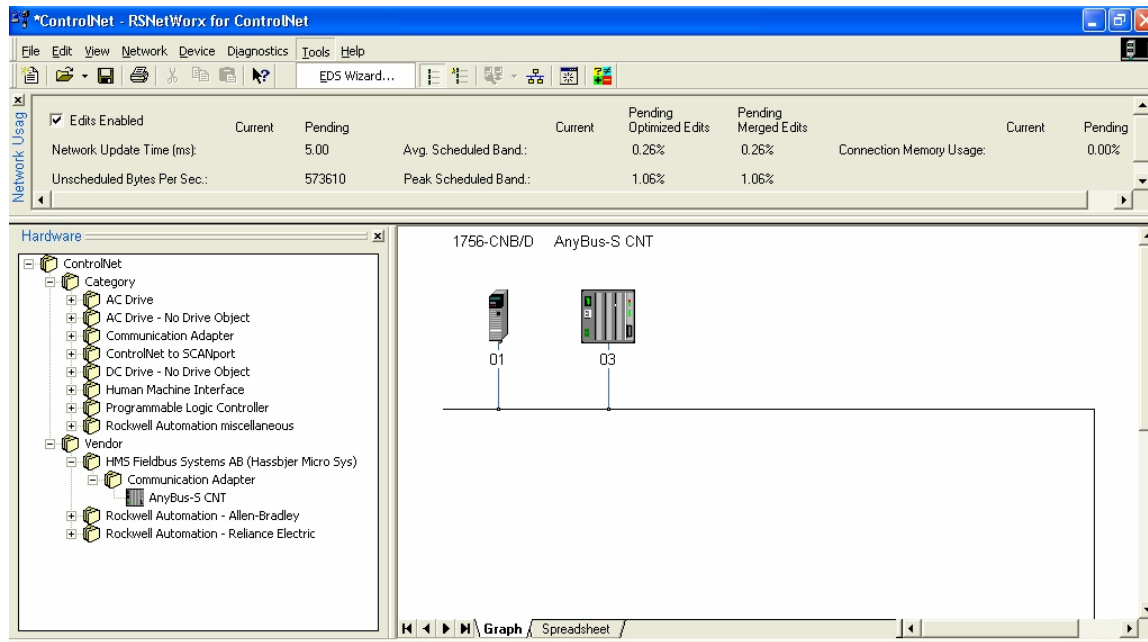

Figure 15 RSNetworkx configuration screen

2. Set the scanner network address using the two rotary switches located on the top of the scanner card. If different hardware is being used, refer to instruction manual for the hardware. This example uses an Allen-Bradley model 1756-CNB/D.
3. The RSNetworkx software queries the network and reads the PLC configuration to generate the proper network configuration.
4. RSNetworkx should see the nodes on the network. The scanner card is the only image you see for the PLC. Enable the edits enabled checkbox to configure the rack and the PLC processor. Right click on the scanner card and choose the edit chassis option. Select the rack, processor and any other cards that are in the PLC.
5. RSNetworkx is used to configure the network update time. Right click in the area outside of the modules, select Properties. Enter the update time and other network parameters as needed. The only requirement is that the network update time is shorter than the PLC Requested Packet Interval. After configuring the rack and setting the network update time, you should have updates pending to the network.
6. A File-Save saves the configuration to your file and to the network at the same time. After the network changes have been saved, the network and the I/O should become healthy. The network and LinkCard LEDs should be solid green.

7. The ControlNet tags can be monitored online using PLC software. Select Controller tags to change the view to display the tags. The tag names match the module name that is being monitored.

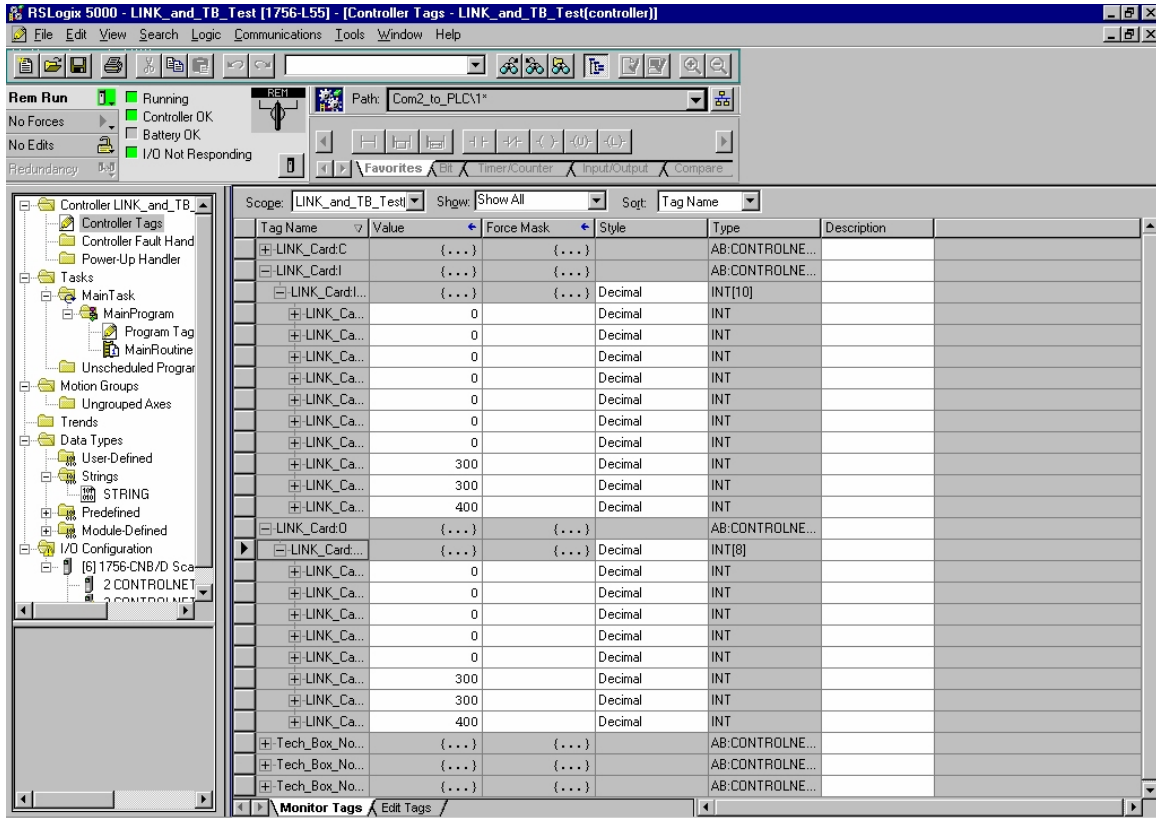

Figure 16 PLC monitor screen

# Appendix A

---

## Configuration Tips

1. Define the total amount of data you wish to send to and from the ControlNet scanner. The limit for the card is 224 words each way. You can have less and the number of inputs and outputs do not have to match. The LINK blocks are 8 words each. Your total words should be a multiple of 8.
2. Inputs are words transmitted from the LINK module to the PLC. These will be LINK writer blocks. Outputs are words transmitted from the PLC to the LINK module. These are LINK reader blocks.
3. The LinkCard transmits two status words so the total number of input words will be your data size plus two.
4. The ControlNet Node Address for the LinkCard is assigned using the DSD software. The rotary switches on the LinkCard are set to 00.
5. The bottom coaxial connector is for the primary ControlNet network.
6. The minimum Network Update Time for the card is 5ms.

## Appendix B Troubleshooting

### L5354 Module Status LED

This bi-color (green - red) LED provides device status. It indicates whether or not the device is powered and operating properly. Table 1 defines the different states of the Module Status LED.

Table 1

<b><u>Status</u></b>	<b><u>LED State</u></b>	<b><u>Reason</u></b>
Power off	Off	<ul style="list-style-type: none"> <li>No power applied to the device</li> <li>Host LINK2 module is not running its configuration</li> <li>Invalid parameters e.g. Mac ID set to 0</li> </ul>
Device in standby	Flashing Green	<ul style="list-style-type: none"> <li>Device needs commissioning because of missing, incomplete or incorrect configuration</li> </ul>
Device operational	Green	<ul style="list-style-type: none"> <li>The device is operating in a normal condition</li> </ul>
Configuration fault	Red	<ul style="list-style-type: none"> <li>After configuration attempt – Module hardware failure</li> </ul>
Device Self-testing	Flashing Red / Green	<ul style="list-style-type: none"> <li>Self test mode</li> </ul>
Device Self-test failure	Flashing Red	<ul style="list-style-type: none"> <li>Device self test failure – may need replacing, try power down/up sequence</li> </ul>

### L5354 Network Status LED

This bi-color (green - red) LED indicates the status of the communications link. Table 2 defines the different states of the Network Status LED.

Table 2

<b><u>Status</u></b>	<b><u>LED State</u></b>	<b><u>Reason</u></b>
Power off or not online	Off	<ul style="list-style-type: none"> <li>The device is not online</li> <li>The device has no ControlNet master</li> <li>The device may not have power applied. Look at rack status LED.</li> </ul>
Online - Not Owned	Flashing Green	<ul style="list-style-type: none"> <li>The device is online with ControlNet master but master is not enabled</li> <li>No connection (not owned) forced listen mode</li> </ul>
Link OK, online, connected	Green	<ul style="list-style-type: none"> <li>The device is online and has connections in the established state</li> <li>Owned by, communicating with, correct configuration between L5354 and the master</li> </ul>
Checking for cable	Flashing Red	<ul style="list-style-type: none"> <li>Cable improperly terminated or connected</li> </ul>
Alive Announcement	Red	<ul style="list-style-type: none"> <li>LinkCard is powered on but in state of waiting for network messages</li> <li>Network not communicating with the LinkCard</li> </ul>
Listen Only	Orange	<ul style="list-style-type: none"> <li>Module forced into listen only mode</li> </ul>
Listen Only	Flashing Orange	<ul style="list-style-type: none"> <li>Duplicate MAC address</li> <li>Module forced into listen only mode</li> </ul>

# Technical Specifications

---

## Environmental

Operating temperature	0° C to 50° C (32° to 122° F)
Storage temperature	-10° C to +70° C (14° to 158° F)
Humidity	85% RAH. in a dry, non-condensing environment
Enclosure Rating	Touchsafe IP20. To be mounted inside a SSD L5300, or L5392 series enclosure

## Supply Voltage

Supply Voltage	5VDC, supplied by backplane
Current Consumption	275 mA @ 5VDC
Power Dissipation	1.375 W

---

## ControlNet

Connection Types	Process Data parameters selected by ControlNet Demand Data protocol to provide random access to any network parameter.
Baud Rate	5 Mbaud
Data Types	Unsigned Integers ( <i>LINK</i> Ordinals)
Indicators supported	Network status bi-color LED, Module status bi-color LED
Transfer delay	Typically < 1 0ms <i>LINK</i> input to ControlNet output and vice-versa
Configurability	LinkCard configuration performed using DSD. ControlNet network and PLC programmed independently
Connector type	Coaxial.

## Physical

Height	120mm (4.72 in)
Width	32mm (1.25 in)
Depth	90mm (3.54in)
Weight	0.16 kg (0.35 lbs)

