

Objective

Provide tips for configuring different Profibus PLC tools used with Eurotherm Drives products

Equipment

Master PLC, Profibus Techbox (6053/6055) or Profibus LinkCard (L5353)

Procedure

ALL PLC CONFIGURING TOOLS:

- Delete all internal software input connections to the drive parameter that the PLC writes to. Otherwise, the internal connection will overwrite the Profibus data to the specified tag number.
- Any drive parameter with a TAG number can be written to or read from. However, all I/O points that attach to customer connections must be processed properly (triggered). Any function block output under the SYSTEM::CONFIGURE I/O::BLOCK DIAGRAM that is being read by the PLC must be triggered. The examples below show how to trigger correctly.

Note: The value for Analog Input 1 is read directly at Setpoint Sum 1::Input 0. The Setpoint Sum 1 block is the trigger for Analog Input 1.

Note: The value for Analog Input 2 is read directly at the miniLINK. The miniLINK block is the trigger for Analog Input 2.

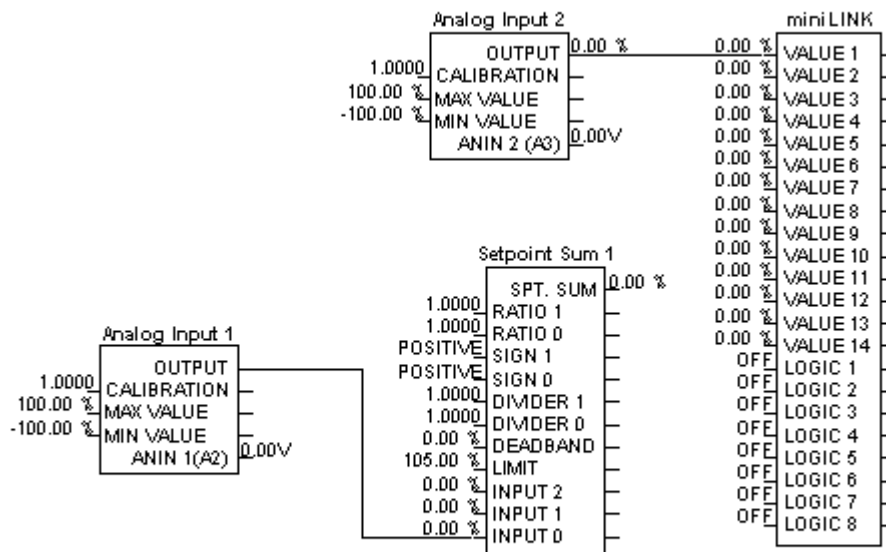

If you have questions, please call the Product Support Group at (704) 588-3246.

- The Eurotherm Drives gsd file forces all parameters to be transferred and received as 16-bits.
- Please visit <http://www.eurothermdrives.com/software/software.htm> for Profibus manuals and other gsd files.

Note: Remember that different configuration tools work differently. Some tools use an import command to install new gsd files. Some copy the gsd to a directory, then either restart the tool or use a scan gsd command. Other tools just copy the gsd to a directory.

Note: The euro3245.gsd requires the first 3 bytes of the User_Param_Data to be set to zeroes. Refer to pages 10 and 11 of HA467329U001 Issue 1.

- Please visit <http://www.eurotherm.com/profibus/gsdnotes.pdf> for other configuring tips.

USING A SIEMENS S7 PLC TO CONFIGURE A L5353

The following Organization Blocks, OB82, OB85, OB06, and OB122 are “highly” recommended to complete the setup for the PLC. These Organization Blocks keep the PLC from stopping communications and/or simulating a fatal error to the module.

Also, uncheck the “Turn on Cyclic Distribution of the Bus Parameters” in the DP monitoring setup. When the PLC has power applied, a Global reset command is initiated and can sometimes simulate a communications error.

USING A GE 90 30 PLC WITH VERSA PRO TO CONFIGURE A 6055/PROF/00

The GE Profibus configuration software (Versa Pro) does not support user parameter data larger than 25 bytes in length. The Eurotherm GSD file specifies 63 bytes of user parameter data for the 590+. Users must alter the Eurotherm GSD before importing to the GE hardware configuration software. The end result is that the amount of data that can be exchanged between the master and drive is limited to 11 words.

GE PLC's do not ground the face of the Profibus interface cards or remote I/O, Siemens does.

Note: An example connection is on the following page

If you have questions, please call the Product Support Group at (704) 588-3246.

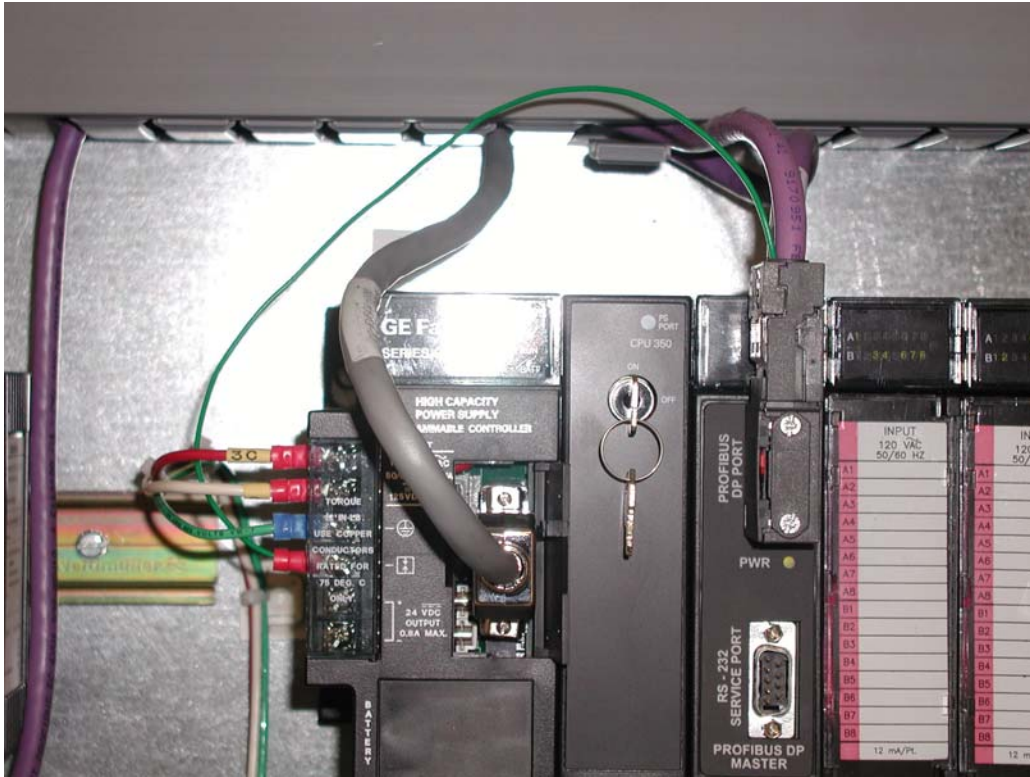

If you have questions, please call the Product Support Group at (704) 588-3246.